

## Rectangular type proximity sensor

### ■ Features

- Improved the noise resistance with dedicated IC
- Built-in reverse polarity protection circuit (DC 3-wire type)
- Built-in surge protection circuit
- Built-in overcurrent protection circuit(DC type)
- Long life cycle and high reliability
- Red LED status indication
- Protection structure IP67(IEC standard)

 Please read "Caution for your safety" in operation manual before using.



### ■ Specifications

#### • DC 2-wire type

- ※The existing PST17 is upgraded its function and design and changed as PSN17.
- ※The case color of Normal Close type is changed from orange to gray.

Model	PSNT17-5DO PSNT17-5DC	PSNT17-5DOU PSNT17-5DCU
Sensing distance	5mm	
Hysteresis	Max. 10% of sensing distance	
Standard sensing target	18×18×1mm(Iron)	
Setting distance	0 to 3.5mm	
Power supply (Operating voltage)	12-24VDC (10-30VDC)	
Leakage current	Max. 0.6mA	
Response frequency <sup>※1</sup>	700Hz	
Residual voltage	Max. 3.5V	
Affection by Temp.	Max. ±10% for sensing distance at ambient temperature 20°C	
Control output	2 to 100mA	
Insulation resistance	Min. 50MΩ(at 500VDC megger)	
Dielectric strength	1500VAC 50/60Hz for 1 minute	
Vibration	1mm amplitude at frequency of 10 to 55Hz(for 1 min.) in each of X, Y, Z directions for 2 hours	
Shock	500m/s <sup>2</sup> (approx. 50G) in each of X, Y, Z directions for 3 times	
Indicator	Operation indicator(red LED)	
Environ-ment	Ambient temperature	-25 to 70°C, storage: -30 to 80°C
	Ambient humidity	35 to 95%RH, storage: 35 to 95%RH
Protection circuit	Surge protection circuit, Overcurrent protection circuit	
Protection	IP67(IEC standard)	
Cable	ø4, 3-wire, 2m (AWG22, Core diameter: 0.08mm, Number of cores: 60, Insulator out diameter: ø1.25)	
Approval	CE	
Unit weight	Approx. 71g	

※1: The response frequency is the average value. The standard sensing target is used and the width is set as 2 times of the standard sensing target, 1/2 of the sensing distance for the distance.

※Environment resistance is rated at no freezing or condensation.

- (A) Photo electric sensor
- (B) Fiber optic sensor
- (C) Door/Area sensor
- (D) Proximity sensor
- (E) Pressure sensor
- (F) Rotary encoder
- (G) Connector/Socket
- (H) Temp. controller
- (I) SSR/ Power controller
- (J) Counter
- (K) Timer
- (L) Panel meter
- (M) Tacho/ Speed/ Pulse meter
- (N) Display unit
- (O) Sensor controller
- (P) Switching mode power supply
- (Q) Stepper motor& Driver&Controller
- (R) Graphic/ Logic panel
- (S) Field network device
- (T) Software
- (U) Other

## ● DC 3-wire type

※The existing PST17 is upgraded its function and design and changed as PSN17.

※The case color of PNP output type is changed from orange to gray.

Model	PS12-4DN PS12-4DP PS12-4DN2 PS12-4DNU PS12-4DPU PS12-4DN2U	PSN17-5DN PSN17-5DP PSN17-5DN2 PSN17-5DP2 PSN17-5DNU PSN17-5DN2U PSN17-5DPU PSN17-5DP2U PSN17-5DN-F	PSN17-8DN PSN17-8DP PSN17-8DN2 PSN17-8DP2 PSN17-8DNU PSN17-8DPU PSN17-8DN2U PSN17-8DP2U	PSN17-8DN-F PSN17-8DP-F PSN17-8DN2-F PSN17-8DP2-F PSN17-8DNU-F PSN17-8DPU-F PSN17-8DN2U-F PSN17-8DP2U-F	PSN25-5DN PSN25-5DP PSN25-5DN2 PSN25-5DP2	PSN30-10DN PSN30-10DP PSN30-10DN2 PSN30-10DP2	PSN30-15DN PSN30-15DP PSN30-15DN2 PSN30-15DP2	PSN40-20DN PSN40-20DP PSN40-20DN2 PSN40-20DP2	PS50-30DN PS50-30DP PS50-30DN2 PS50-30DP2
Sensing distance	4mm	5mm	8mm	5mm	10mm	15mm	20mm	30mm	
Hysteresis	Max. 10% of sensing distance								
Standard sensing target	12×12×1mm (Iron)	18×18×1mm (Iron)	25×25×1mm(Iron)			30×30×1mm (Iron)	45×45×1mm (Iron)	60×60×1mm (Iron)	90×90×1mm (Iron)
Setting distance	0 to 2.8mm	0 to 3.5mm	0 to 5mm		0 to 3.5mm	0 to 7mm	0 to 10.5mm	0 to 14mm	0 to 21mm
Power supply (Operation voltage)	12-24VDC (10-30VDC)								
Current consumption	Max. 10mA								
Response frequency※1	500Hz	700Hz	200Hz		300Hz	250Hz	200Hz	100Hz	50Hz
Residual voltage	Max. 1.5V								
Affection by Temp.	Max. ±10% for sensing distance at ambient temperature 20°C								
Control output	Max. 200mA								
Insulation resistance	Min. 50MΩ(at 500VDC megger)								
Dielectric strength	1500VAC 50/60Hz for 1minute								
Vibration	1mm amplitude at frequency of 10 to 55Hz(for 1 min.) in each of X, Y, Z directions for 2 hours								
Shock	500m/s <sup>2</sup> (approx. 50G) in each of X, Y, Z directions for 3 times								
Indicator	Operation indicator(red LED)								
Environment	Ambient temperature	-25 to 70°C, storage: -30 to 80°C							
	Ambient humidity	35 to 95%RH, storage: 35 to 95%RH							
Protection circuit	Surge protection circuit, Overcurrent protection circuit, Reverse polarity protection circuit								
Protection	IP67(IEC standard)								
Cable	ø4, 3-wire, 2m								ø5, 3-wire, 2m
	(AWG22, Core diameter: 0.08mm, Number of cores: 60, Insulator out diameter: ø1.25)								
Material	Case: Heat-resistant ABS, Standard cable(Black): Polyvinyl chloride(PVC).								
Approval	CE								
Unit weight	Approx. 62g	Approx. 71g	Approx. 70g			Approx. 111g	Approx. 185g	Approx. 220g	

## ● AC 2-wire type

※The case color of Normally Closed type is changed from orange to gray.

Model	PSN25-5AO PSN25-5AC	PSN30-10AO PSN30-10AC	PSN30-15AO PSN30-15AC	PSN40-20AO PSN40-20AC
Sensing distance	5mm	10mm	15mm	20mm
Hysteresis	Max. 10% of sensing distance			
Standard sensing target	25×25×1mm(Iron)	30×30×1mm(Iron)	45×45×1mm(Iron)	60×60×1mm(Iron)
Setting distance	0 to 3.5mm	0 to 7mm	0 to 10.5mm	0 to 14mm
Power supply(Operating voltage)	100-240VAC(85-264VAC)			
Leakage current	Max. 2.5mA			
Response frequency※1	20Hz			
Residual voltage	Max. 10V			
Affection by Temp.	Max. ±10% for sensing distance at ambient temperature 20°C			
Control output	5 to 200mA			
Insulation resistance	Min. 50MΩ(at 500VDC megger)			
Dielectric strength	1500VAC 50/60Hz for 1 minute			
Vibration	1mm amplitude at frequency of 10 to 55Hz(for 1 min.) in each of X, Y, Z directions for 2 hours			
Shock	500m/s <sup>2</sup> (approx. 50G) in X, Y, Z direction for 3 times			
Indicator	Operation indicator(red LED)			
Environment	Ambient temperature	-25 to 70°C, storage: -30 to 80°C		
	Ambient humidity	35 to 95%RH, storage: 35 to 95%RH		
Protection circuit	Surge protection circuit			
Protection	IP67(IEC standard)			
Cable	ø4, 2-wire, 2m(AWG22, Core diameter: 0.08mm, Number of cores: 60, Insulator out diameter: ø1.25)			
Approval	CE			
Unit weight	Approx. 65g	Approx. 106g		Approx. 152g

※1: The response frequency is the average value. The standard sensing target is used and the width is set as 2 times of the standard sensing target, 1/2 of the sensing distance for the distance.

※Environment resistance is rated at no freezing or condensation.

## ■ Dimensions

(unit: mm)

### ● PS12

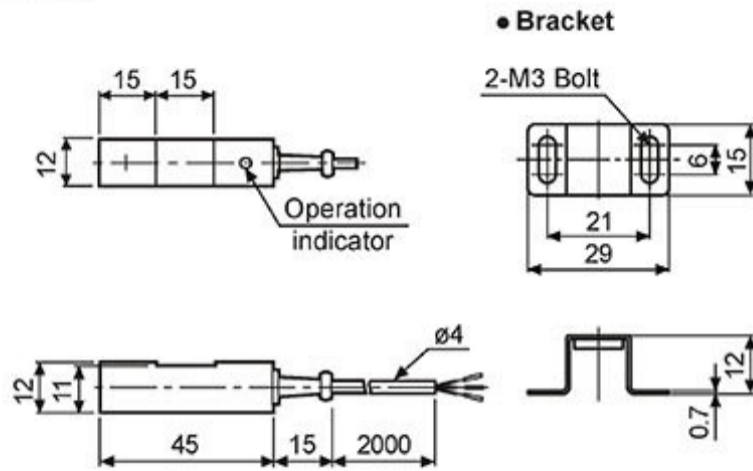

### ● PSN25

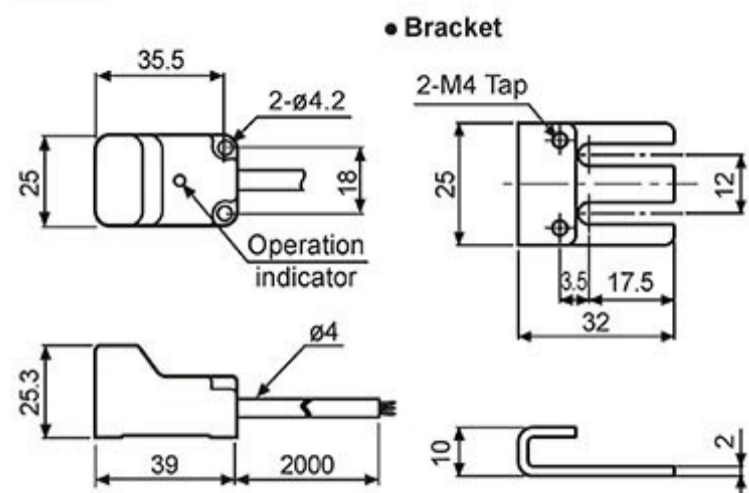

### ● PSN17 / PSNT17(former : PS17/ PST17)

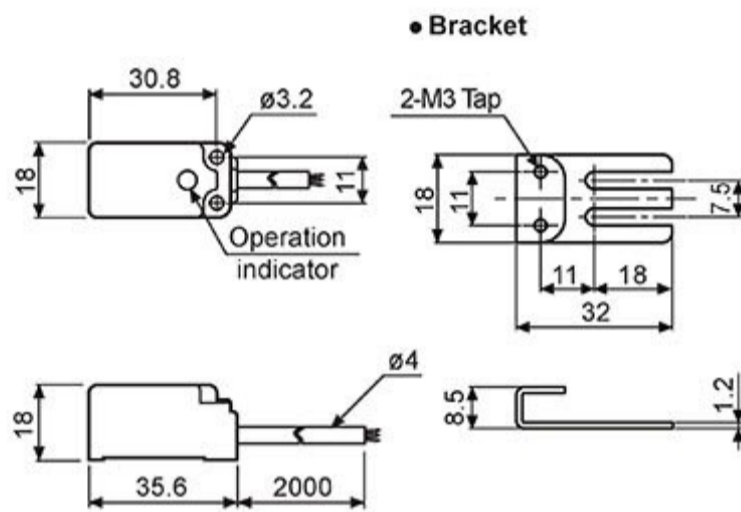

### ● PSN30

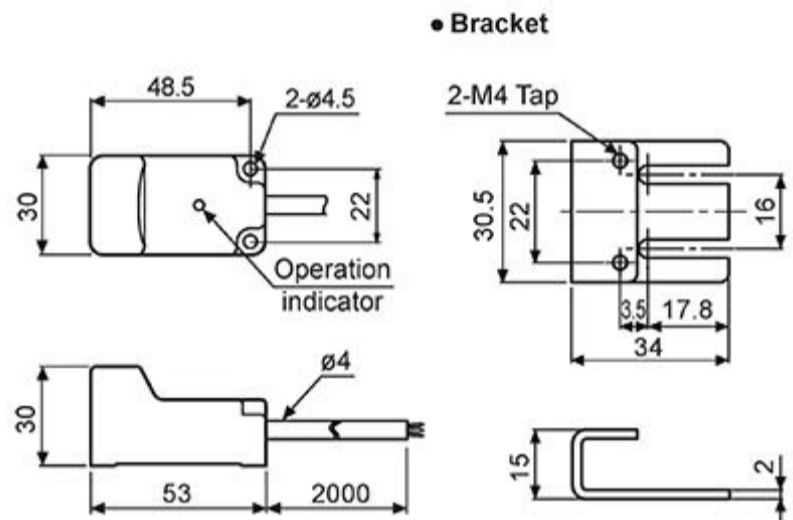

### ● PS50

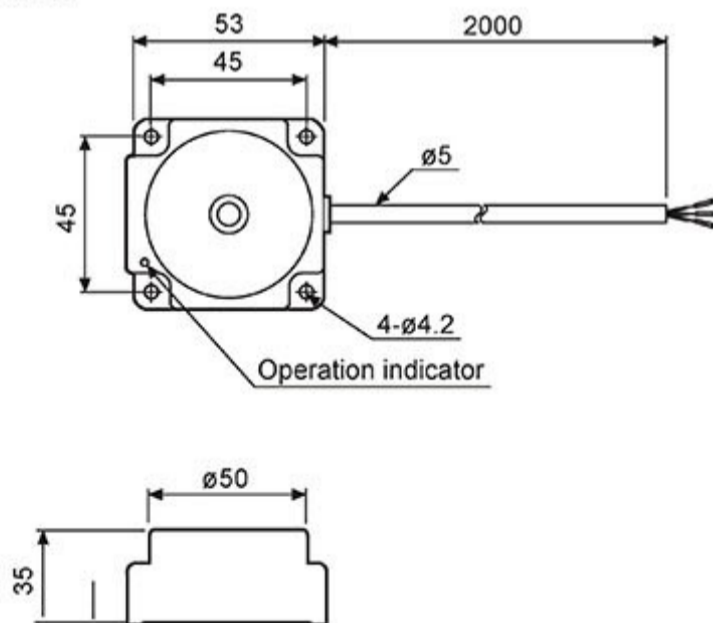

### ● PSN40

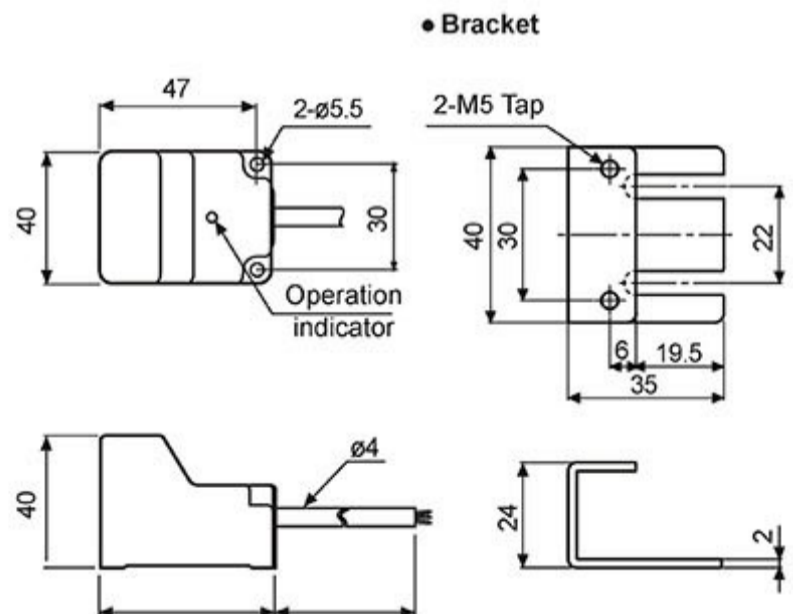

(A) Photo electric sensor

(B) Fiber optic sensor

(C) Door/Area sensor

(D) Proximity sensor

(E) Pressure sensor

(F) Rotary encoder

(G) Connector/Socket

(H) Temp. controller

(I) SSR/ Power controller

(J) Counter

(K) Timer

(L) Panel meter

(M) Tacho/ Speed/ Pulse meter

(N) Display unit

(O) Sensor controller

(P) Switching mode power supply

(Q) Stepper motor& Driver&Controller

(R) Graphic/ Logic panel

(S) Field network device

(T) Software

(U) Other

## ■ Control output diagram

### ◎ DC 3-wire type

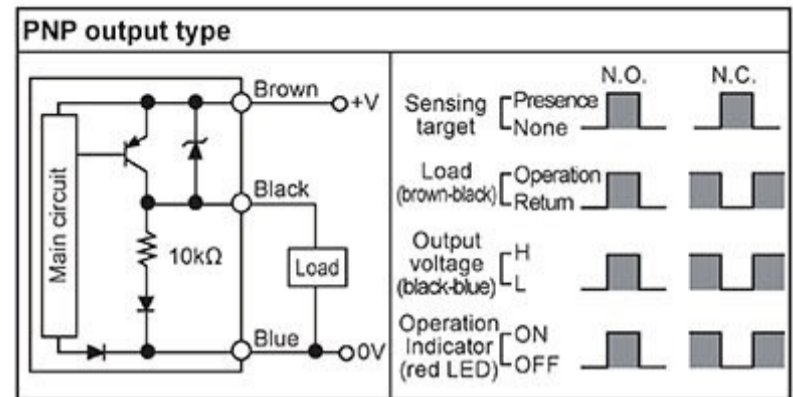
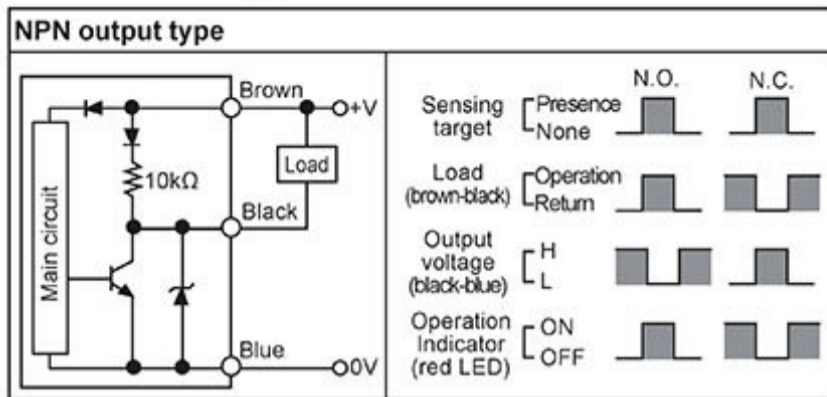

### ◎ DC 2-wire type

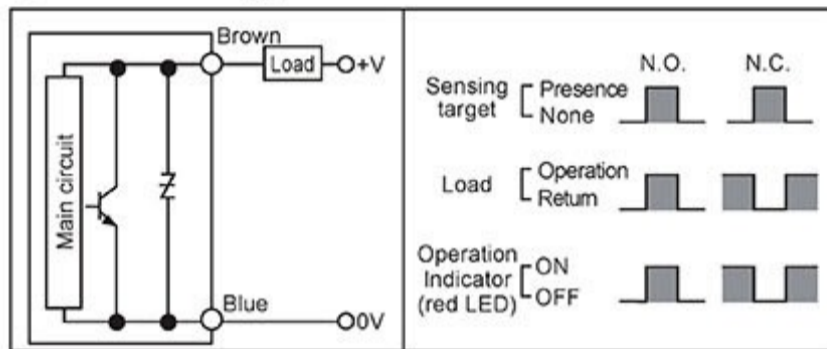

### ◎ AC 2-wire type

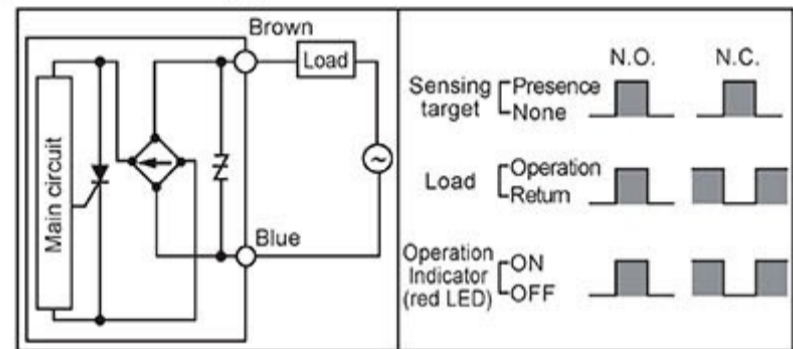

## ■ Connections

### ◎ DC 3-wire type

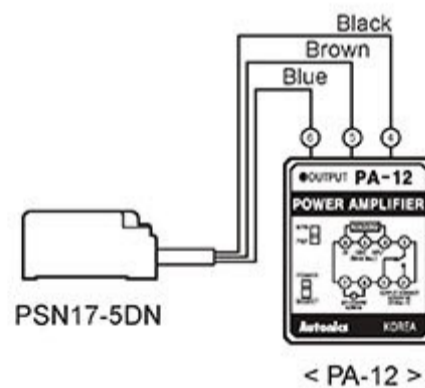
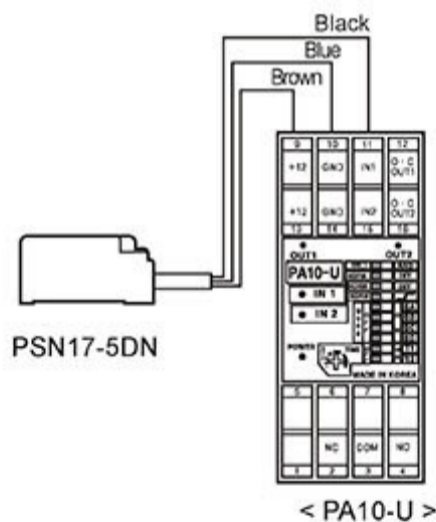

※ There is NPN/PNP selection switch in PA-12.

### ◎ DC 2-wire type

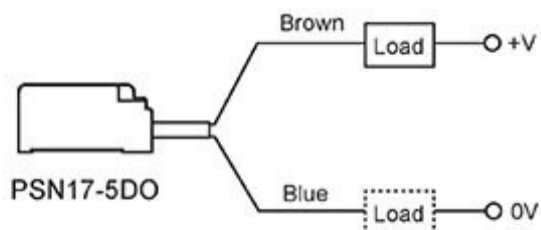

※ The load can be connected to either wire.

### ◎ AC 2-wire type

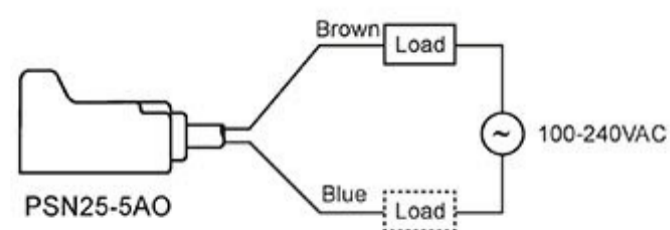

※ The load can be connected to either wire.

## ■ Proper usage

### ◎ Differential frequency

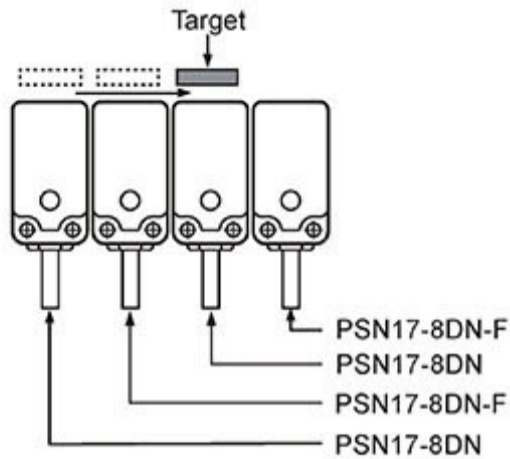

When installing several proximity sensor closely, it may cause malfunction due to mutual interference. Therefore, please use differential frequency for the application  
 ※Differential frequency type is only for 17 square.

### ◎ In case of the load current is small

#### ● AC 2-wire type

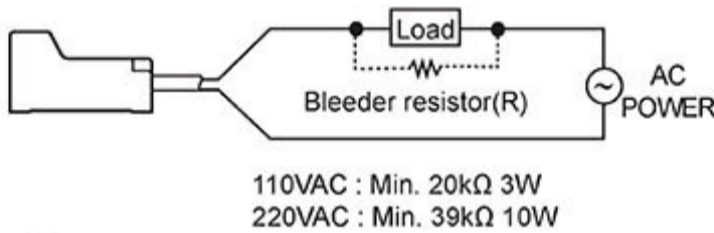

#### ● DC 2-wire type

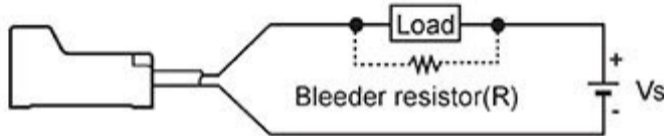

### ◎ Connection of the power supply

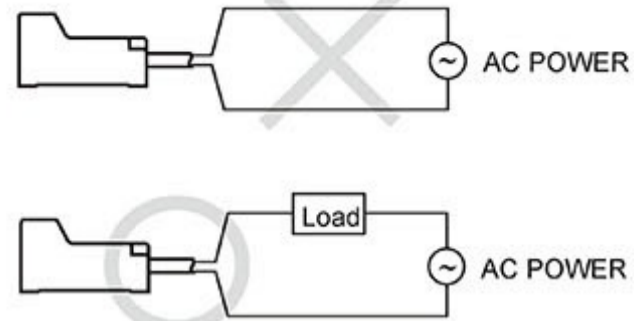

When using DC 2-wire and AC 2-wire type, a load must be connected before applying power; otherwise, components can be damaged.

It may cause return failure of load by residual voltage. If the load current is under 5mA, please make sure the residual voltage is less than the return voltage of the load by connecting a bleeder resistor in parallel with the load as shown in the diagram.

$$R = \frac{V_s}{I} (\Omega) \quad P = \frac{V_s^2}{R} (W)$$

[ I: Action current of load, R: Bleeder resistance, P: Permissible power]

Please make the current on proximity sensor smaller than the return current of load by connecting a Bleeder resistor in parallel.

※W value of Bleeder resistor should be bigger for proper heat dissipation.

$$R = \frac{V_s}{I_o - I_{off}} (\Omega) \quad P = \frac{V_s^2}{R} (W)$$

[ Vs : Power supply, I<sub>o</sub> : Min. action current of proximity sensor  
 I<sub>off</sub> : Return current of load, P : Number of Bleeder resistance watt ]

### ◎ Mutual-interference & Influence by surrounding metals

When several proximity sensors are mounted close to one another a malfunction of the may be caused due to mutual interference. Therefore, be sure to provide a minimum distance between the two sensors as below chart indicates.

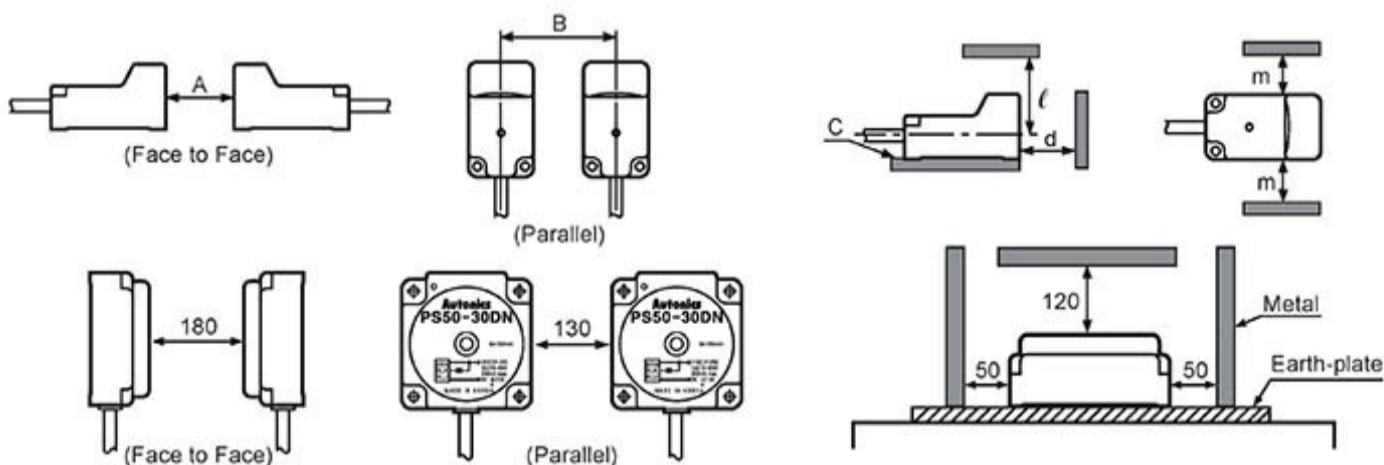

(unit: mm)

Item	Model	PSN17 / PSNT17		PSN25	PSN30		PSN40	
		4mm	5mm	8mm	5mm	10mm	15mm	20mm
A		24	30	48	30	60	90	120
B		24	36	40	40	50	65	70
C		5	5	5	5	5	5	5
d		12	15	24	15	30	45	60
l		18	24	33	25	30	45	45
m		12	18	20	20	25	35	35

- (A) Photo electric sensor
- (B) Fiber optic sensor
- (C) Door/Area sensor
- (D) Proximity sensor
- (E) Pressure sensor
- (F) Rotary encoder
- (G) Connector/Socket
- (H) Temp. controller
- (I) SSR/Power controller
- (J) Counter
- (K) Timer
- (L) Panel meter
- (M) Tacho/Speed/ Pulse meter
- (N) Display unit
- (O) Sensor controller
- (P) Switching mode power supply
- (Q) Stepper motor& Driver&Controller
- (R) Graphic/ Logic panel
- (S) Field network device
- (T) Software
- (U) Other